

# COMPACT 3

## Automatic Device for electric pump integral control

**COMPACT 3** is a compact device for the automatic control and protection of electric pumps, its patented system includes special electronic sensor of flow and pressure, integrated in electronic circuit that guides the electric pump operation and keeps pressure and flow accordingly. Moreover, it has a safety system to avoid the dry-running operation.

**COMPACT 3** replaces traditional systems with hydrosphere, pressure-switch, non-return valve and level switches, with the advantage of smaller dimensions and avoiding periodic maintenance. The unit automatically starts the electric pump when any point of use is open and stop it –after a 10 seconds programmed time– when closing the consumption point.

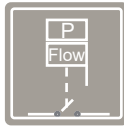

**COMPACT 3 F15**

**COMPACT 3 F25**

## OPERATING CHARACTERISTICS

- No maintenance.
- Installation time saving.
- Protection against water hammer effect.
- Compact and reduced dimensions.
- Removal of protecting devices (level switches).
- Avoids the pump oversizing using integrately their flowpressure curve.
- Integrated protection system which stops the pump in case of dry-running operation.
- **ART function** (Automatic Reset Test). If the device has been stopped due to the action of the safety system against dry operation, the ART tries to connect the pump, with a programmed periodicity because the water supply could have been restored.
- Control panel:
  - Yellow Led POWER.
  - Green Led ON.
  - Red Led FAILURE.
  - Tactile push button for manual start.
- Electronic circuit group with protection cover easily replaceable.
- Hydraulic connections G1" (NPT 1" on request).
- Integrated accumulation system, spring-membrane set, preventing pump's cycling as a result of dripping taps or small losses in the hydraulic installation.
- Other options like pressure gauge, connecting cables.



Low Voltage Directive 2014/35/EC  
Electromagnetic Compatibility 2014/30/EC  
RoHS 2011/65/EC + 2015/863/EC

## TECHNICAL CHARACTERISTICS

	F15	F25
Start pressure	1,5 bar	2,5 bar
Power	1,5 kW	
Voltage	~1 x 110÷230 Vac	
Frequency	50/60 Hz	
Max peak of current	10 A; cos fi ≥0.6	
Protection degree	IP65	
Maximum temperature	50 °C	
Maximum pressure	10 bar	
Maximum flow	8.000 l/h	
Net weight (without cables)	0,9 Kg	

## CONTROL PANEL

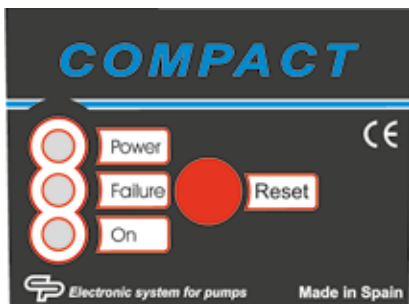

## DIMENSIONS

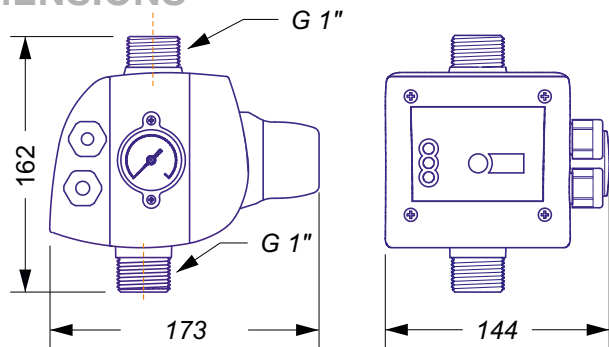

## INSTALLATION

